

BBETM
Sound Inc.

MODEL 822A
USER MANUAL

5500 Bolsa Ave., Suite 245
Huntington Beach, CA 92649. (714) 897-6766
in USA (800) 233-8346, in CA (800) 558-3963
FAX (714) 895-6728
BBE is a Registered Trademark of BBE Sound, Inc.

Important Safeguards

For your protection, please read these safety instructions completely before operating the appliance, and keep this manual for future reference.

Carefully observe all warnings, precautions and instructions on the appliance and described in the operating instructions supplied with the appliance.

INSTALLATION

Water and Moisture — Do not install the appliance near water, for example, near a bathtub, washbowl, kitchen sink, laundry tub, in a wet basement, or near a swimming pool.

Heat — Do not install the appliance near sources of heat such as radiators, heat registers, stoves, or other appliances that produce heat.

Wall or Ceiling Mounting — If your appliance can be mounted to a wall or ceiling, mount it only as recommended.

USE

Power Source — Connect the appliance to a power supply only of the type described in the operating instructions or as marked on the appliance.

Grounding or Polarization — Do not defeat the grounding or polarization feature of the AC power cord. If your AC receptacle will not accept the power cord plug, contact your electrician to install a proper AC receptacle.

AC Receptacle — Check to make sure that the AC receptacle holds the power cord plug firmly and securely. If the Power cord plug is loose, contact your electrician to replace the defective and unsafe AC receptacle.

Power-Cord Protection — Route the power cord so that it is not likely to be walked on or pinched by having objects placed on it, paying particular attention to the plugs, receptacles, and the point where the cord exits from the appliance.

When not in use — Unplug the power cord of the appliance from the outlet when left unused for a long period of time.
To disconnect the cord, pull it out by grasping the plug. Never pull the plug out by the cord.

Foreign Objects — Be careful that foreign objects and liquids do not enter the enclosure through openings.

SERVICE

Unplug the appliance from the wall outlet and consult qualified service personnel when:

- the power cord or the plug has been damaged.
- a solid object or liquid has fallen into the cabinet.

- the appliance has been exposed to rain or moisture.
- the appliance does not appear to operate normally or exhibits a marked change in performance.

- the appliance has been dropped, or the enclosure damaged.

Do not attempt to service the appliance beyond that described in the operating instructions. For all other servicing refer to qualified service personnel only.

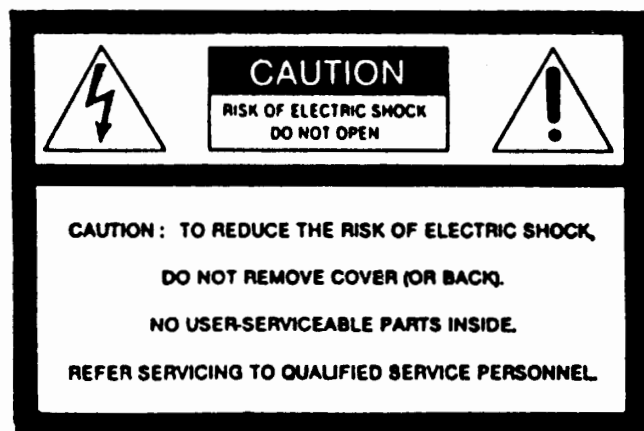

WARNING

To prevent fire or shock hazard, do not expose the unit to rain or moisture.

ATTENTION: RISQUE DE CHOC ELECTRIQUE – NE PAS OUVRIIR.



The lightning flash with arrowhead symbol, within an equilateral triangle, is intended to alert the user to the presence of uninsulated "dangerous voltage" within the product's enclosure that may be of sufficient magnitude to constitute a risk of electric shock to persons.



The exclamation point within an equilateral triangle is intended to alert the user to the presence of important operating and maintenance (servicing) instructions in the literature accompanying the appliance.

Congratulations

Thank you for buying the BBE Model 822A Audio Processor. You now own a very unique signal processing device with no other equal in the audio world today. Whether you purchased the BBE 822A for recording studio, live concert, playback or industrial use, you will find the unit's rugged construction and careful electronic design a welcome addition to your audio system.

This manual will help you use the BBE 822A more effectively and in ways of which you may not be aware. Review of the information contained in this owner's manual will answer most of the common questions that our service department receives. But if you have a question, please feel free to call toll-free (US) 800-233-8346 or (CA) 800-558-3963.

The BBE™ Process — “What Is It?”

Loudspeakers have difficulty dealing with the electronic signals supplied by an amplifier. These difficulties cause such major phase and amplitude distortion that the sound reproduced by a speaker differs significantly from the sound produced by the original source.

In the past, these problems have proved unsolvable and were thus relegated to a position of secondary importance in audio system design. However, phase and amplitude integrity is essential to accurate sound reproduction. Research shows that the information which the listener translates into the recognizable characteristics of a live performance are intimately tied into the complex time and amplitude relationships between the fundamental and harmonic components of a given musical note or sound. These relationships define a sound's “sound.”

When these complex relationships pass through a speaker, the proper order is lost. The higher frequencies are delayed. A lower order frequency may reach the listener's ear first or perhaps simultaneously with that of a higher frequency. In some cases, the fundamental components may be so time-shifted that they can reach the listener's ear ahead of some or all the harmonic components.

This change in the phase and amplitude relationship of the harmonic and fundamental frequencies is technically called “envelope distortion.” The listener perceives this loss of sound integrity in the reproduced sound as “muddy” and “smeared.” In the extreme, it can become difficult to tell the difference among musical instruments, for example, an oboe and a clarinet.

BBE Sound, Inc. conducted extensive studies of numerous speaker systems over a ten year period. With this knowledge it became possible to develop an ideal speaker and to distill the corrections necessary to return the fundamental and harmonic frequency structures to their correct order. While there are differences among various speaker designs in the magnitude of their needs for correction, the overall pattern of correction needed is remarkably consistent.

The BBE™ process is so unique that 42 patents have been awarded by the U.S. Patent Office.

“How It Works”

The BBE process imparts a pre-determined phase correction to the high frequencies where most harmonic information exists. This is done by breaking the signal into three sub-bands or groups: the low frequency group which is crossed over at 150Hz, the mid-range group which is crossed over at 1200Hz and the high frequency group that handles everything else up to 20kHz.

The low group is delayed about 2.5 ms (milliseconds) via group delay within a passive low pass filter. The front panel control allows for either a flat response, reduction or boost of the lows at 50Hz.

The mid-range group is delayed only about 0.5 ms and passes through an active band pass filter. The mid group is used as a point of reference to make dynamic amplitude corrections in both positive and negative directions to the high frequency group which has been passed through a high quality VCA (Voltage Controlled Amplifier).

Two RMS average loudness detectors continuously monitor both the mid-range and high frequencies to compare the relative harmonic content levels of the two bands and apply the appropriate amount of control voltage to the VCA, thereby determining the amount of high frequency harmonic content present at the final output of the BBE processor.

Product Description

The BBE 822A is an intelligent audio processor designed to solve a series of complex problems as described in the previous section. It is, however, very simple to set up and operate and once installed will function flawlessly without further attention.

It is a dual channel, rack-mountable device for use in +4dBu balanced line level applications, such as those found in recording studios, large concert systems and industrial audio applications. The BBE 822A takes up one EIA standard rack space of 19 inches width and 1.75 inches height (1U). There are two completely separate channels to allow for either full stereo program or two independent mono channels, such as separate processing for a snare drum tape track in channel A and a synthesized bass track in channel B.

BBE applies different phase correction algorithms to three separate frequency bands. A variable front panel control for each channel allows the user to adjust the amount of process desired.

Using Your New BBE 822A

BBE is a process to be added before all other mixing of reverb, special effects or equalization. The BBE 822A should be used to increase the clarity and intelligibility of the total finished mix or an individual track, ie. vocal or instrument.

Unlike many aural exciters and equalizers, the BBE 822A will not add any extra noise or harmonics to the sound. Thus, there will be no future problems in duplication or mastering caused by aberrant high frequency distortion. Since the BBE technology is a single-stage process, there is no need for encoding or decoding.

Always "A - B" the processed to unprocessed sound with the process in/out switch to adjust the amount of processing required.

Things to Remember

The BBE 822A is designed to work in a line-level environment. The program average levels feeding the input of the unit should be around "0" VU or anywhere from -20dBu to +8dBu. The BBE 822A drives load impedances down to 600 Ohms and supplies up to +23dBu levels at which point it will clip. The BBE 822A accepts both unbalanced and balanced inputs and supplies floating outputs on the XLR connections. Both the inputs and outputs are active balanced while having the tip on ¼" jacks hot.

If the program material has excessive background noise, the noise may be modulated with the program. In this case, an equalizer or other type of noise reduction system may be inserted in front of the BBE 822A to roll off the noise first.

Applications

Various applications of the BBE process include:

Recording Studios

The BBE 822A is designed for use in professional studios to restore liveness, clarity, and improve the transient response of individual tracks or entire two channel mixes. The patented BBE process works especially well on digital drum machines, on synthesized brass patches and on vocals where extreme equalization would cause stridency and distortion at peak levels. The BBE 822A works as a playback processor when inserted between the tape track output and the console line input. Conversely, when recording with the BBE 822A the output of the console feeds directly to the input of the BBE 822A. The BBE 822A's output then feeds the tape recorder's input. The BBE 822A saves poorly recorded or over-compressed tape tracks and brightens low-level instruments without bringing up a lot of noise in the process. Figure 1 shows the BBE 822A in a typical recording studio application where the recording buss output to the tape track is interrupted and the BBE 822A inserted.

Live Concert Systems

The BBE 822A adds much needed clarity to the monitor mix without shrillness. The two independent channels are ideal for two monitor mixes when one mix requires more processing level than the other.

Figure 2A shows the BBE 822A in a typical concert sound system where channel A of the BBE 822A is used for the main house mix feed and channel B is used for the monitor mix feed when two different amounts of processing are required along with the two different mixes. The BBE 822A should be placed **before** any house graphic equalizers. All pink noise checks should be made with the BBE unit switched "out" to obtain the desired house curve. The BBE process can then be dialed in to suit the music production. Extreme console equalization normally used during live performance may be reduced due to the dynamic enhancement effect of the BBE 822A.

The BBE 822A may be inserted in many places within the console's signal path to achieve specialized results. In the case of non-VCA sub-groups, the BBE 822A is inserted between "buss out" and "sub-group fader in" for the application of the BBE process to a whole group of drum microphones, for example.

Figure 2B shows the BBE process being used on only one microphone source. The BBE 822A is then inserted in the normal "insert send and receive" points exactly like a limiter or equalizer is patched.

If the P.A. mixer does **not** have "insert points" or if the mixer is a powered type unit without any way of interrupting the signal path before the power amplifier then the BBE 411 for a Hi-Z microphone should be used. The BBE 411 accepts low levels from microphones, etc. and interfaces directly to the P.A. mixer.

Audio Cartridge/Cassette Copies

Since the BBE technology is a single stage process without the need for encoding and decoding, the stereo BBE 822A is inserted between the master two-track and the audio cartridge or cassette recorder for crisper punchier copies. Figure 3 shows the BBE 822A in real time cartridge or cassette copy mode.

In the case of high-speed cassette duplication, the BBE process must be applied when the equalized cassette master dub is made at the mastering studio. See Mastering.

Mastering

The BBE 822A is used in the mastering of vinyl record, audio cassettes and digital compact discs to dramatically increase the clarity of the program material. Mastering engineers generally use much less equalization when the BBE 822A is used. Once again, the BBE 822A is inserted between the master tape reproducer and the mastering console.

Industrial

The BBE 822A greatly improves intelligibility in speech or music programs by improving transient playback response. This makes the BBE 822A a natural for public address, intercom or wide area dispersion of pre-recorded music or voice announcements over an existing old and dull loudspeaker system. Figure 4 shows the BBE 822A inserted between the telephone matching adapter and the auxiliary input to the public address intercom amplifier. Since the BBE 822A is a line level operated device, plugging a microphone directly into the unit will not work. If the existing P.A. amplifier has no provision for auxiliary input, then the BBE 411 unit should be used. The BBE 411 unit accepts a microphone directly and then interfaces with an existing P.A. amplifier without costly on-site modifications.

Broadcast

The BBE 822A is perfect for "on the air" audio enhancement when inserted after the studio mixing console before the final peak limiters.

Figure 5 shows a typical BBE 822A installation at the broadcast station. Usually a separate BBE 822A would be integrated into each engineer's booth adjacent to the mixing console. The BBE 822A reduces the high and mid frequency smear for clearer, less strident high end and more distinct mid range. The BBE 822A is also used in the production of music and commercial tape cartridges to make cleaner and crisper copies.

Movie Theater

The BBE process brings film and sound tracks which feature a wide range of special effects to dramatic life. It also adds sparkle and intelligibility to dull and mussy optical film sound. Both music and dialogue take on a fresh, bright character when processed through the BBE 822A.

Figure 6 shows the BBE 822A in a typical movie theater application inserted after the Dolby Surround Processor™ directly in front of the theater's speaker power amplifiers. A four channel theater requires two BBE 822As while six channel houses require three BBE 822As. The "set and forget" adjustments on the BBE 822A mean the theater operator does not need to rely on the projectionist for proper BBE operation.

Disco/Club

Figure 7 shows the BBE 822A in a disco club application. Usually, the same rules mentioned in live concert systems apply but on a smaller scale. The ideal place to insert the BBE 822A is between the "main program buss out" and the master volume control. Not all disco club mixers have this facility, so the next best place is at the power amplifier. The output of the mixer feeds the BBE 822A's input and the output of the BBE feeds the power amplifier. The BBE 822A unit is set to accommodate the loudest levels used.

The Controls

Operation of the BBE 822A is quite simple due to the sophisticated circuitry within the unit. The purpose of each control on the BBE 822A is outlined below.

FRONT PANEL

- Lo Contour Control** Each channel has a lo contour control that regulates the amount of phase compensated bass equalization. This adjustment ranges from -12dBu (fully counterclockwise) to $+10\text{dBu}$ (fully clockwise) at 50Hz relative to the input. The middle position is flat or unity gain.
- Definition Control** Each channel has a definition control that regulates the amount of amplitude compensation as indicated by the hi contour LED stack. Set to minimum (fully counterclockwise) yields a flat frequency response with phase compensation only. Turning clockwise increases the amplitude of the high frequency band relative to the mid band amplitude providing an improved spectral balance between the high and mid bands.
- Hi Contour LED Stack** Each channel is equipped with a set of LED indicators that instantly show the relative amount of high band compensation as compared to the mid band.
- 1) RED LED (marked "-"): Compression mode. The amplitude of the high band is too high as compared to the mid band and compression is being applied to compensate.
 - 2) AMBER LED (marked "0"): Flat mode. No amplitude compensation is needed. The program spectral content is correct.
 - 3) GREEN LED (marked "+"): Expansion mode. The amplitude of the high band is too low as compared to the mid band and is being expanded to compensate.
 - 4) CLIP LED: This LED indicates that the output of the BBE 822A has reached the maximum level of $+20\text{dBu}$. (The clip LED will light $+3\text{dBu}$ prior to true clip on the BBE 822A)
- Function Switch** This function push button switch allows for a quick comparison of processed with unprocessed sound. When the switch is depressed, the green "IN" LED lights. When the switch is out, the amber "OUT" LED lights. In the function "OUT" mode, the audio signal goes through a single piece of wire and a set of sealed relay contacts – no noisy switches or pots.
- Process Switch** In the "Auto" mode, the BBE 822A provides dynamic response to the high frequency band in relation to the mid band. This in turn will allow the BBE process to either expand or compress the high band.
- The "Manual" mode, on the other hand, provides for a factory preset expansion ratio for the high band. Both modes are controlled by the definition and lo-contour controls. "Auto" mode would be considered normal operation.
- Power Switch** This switch controls primary power to the BBE 822A.

REAR PANEL

- AC Power Cord Fuse** Plugs into AC power receptacle. Turn cap on fuse holder counterclockwise to remove fuse. (Note: replace with 250VAC, 1/2A type fuse.)
- Lo-Z Balanced Output** Each channel is equipped with a 3-pin, male, XLR type connector that is a low impedance, balanced, line-level output. Normally connected to a power amp input, it is capable of delivering $+23\text{dBu}$ into 600 ohms.
- Hi-Z Unbalanced/Balanced Output** Each channel is equipped with a high impedance, tip-ring-sleeve 1/4" phone jack output that may be used for either balanced or unbalanced applications. This line level output is capable of delivering $+23\text{dBu}$ into 600 ohms.
- Lo-Z Balanced Input** Each channel is equipped with a 3-pin, female, XLR type connector that accepts a low impedance, balanced, line-level input with an average level of $+4\text{dBu}$ normally from a mixer output. (Note: $+23\text{dBu}$ is the maximum input before clipping.)
- Hi-Z Unbalanced/Balanced Input** Each channel is equipped with a high impedance, tip-ring-sleeve 1/4" phone jack input that may be used for either balanced or unbalanced applications. This line level input accepts $+4\text{dBu}$ average line levels normally from a mixer output. (Note: $+23\text{dBu}$ is the maximum input before clipping.)

Set-Up

The BBE 822A is connected into the audio chain in series with the signal path — the same way a graphic equalizer or limiter is connected. The output of the mixer, pre-amp or tape recorder feeds the input of the BBE 822A. The input level should fall within the nominal range as outlined in the specifications.

Setting-up and using the BBE 822A as an echo send device like a digital reverb is **not** recommended. The processing effect is not fully realized when the output of the BBE 822A is summed with the original source audio.

Specifications BBE 822A

Frequency Response	
Bypass	DC to 20kHz
Process Mode	program controlled
Noise in Process Mode	- 85dBu below 0dBu output level
Total Harmonic Distortion in process mode	less than 0.1% @1kHz @ +4dBu
Input Characteristics	
Input Impedance	10K Ohms (balanced or unbalanced)
Nominal Input Range	- 10dBu to +8dBu
Maximum Input Level	- 23dBu (input clip point)
Output Characteristics	
Minimum Load Impedance for Full Output	600 Ohms (balanced or unbalanced)
Nominal Output Level	- 10dBu to +8dBu
Maximum Output Level	+ 23dBu into 600 Ohm Load (clip point)
Output Impedance	600 Ohms (balanced or unbalanced)
Power Requirements	
120VAC (nominal) 50/60Hz	8 watts
A/C Line Fused protected	
Terminations/Connectors	
Rear Panel	XLR and 1/4" Tip-Ring-Sleeve (Tip is hot)
Dimensions	
1 3/4"H x 17"W x 7"D	Standard 1U single rack
Weight	
6 lbs.	

Note: 0dBu = 0.77Vrms

ALL SPECIFICATIONS SUBJECT TO CHANGE WITHOUT NOTICE

CALIBRATION PROCEDURE FOR BBE™ MODEL 822A FOR SERIAL NUMBERS EXXXXX REVISION L

EQUIPMENT REQUIRED:

- 1) Audio Signal Generator (sine wave)
- 2) Two digital voltmeter (DVM #1 and DVM #2)

INITIAL SETTINGS:

- 1) DEFINITION control to minimum (completely counter clockwise).
- 2) LO-CONTOUR control and all internal potentiometers to their middle positions.
- 3) FUNCTION to IN and POWER to ON.

Since both channels are identical in calibration and component numbers only channel A will be outlined.

All tests are done with a signal level of -10dBu (0.245Vrms) except for the CLIP test.

The signal will be input into the corresponding channel connector marked INPUT (¼" phone jacks unbalanced).

The DVM #1 will monitor the output of the corresponding channel marked OUTPUT (¼" phone jack unbalanced).

The DVM #2 will be used to measure various test points in the test procedure. (relative to ground)

PROCEDURE:

OFFSET ADJUSTMENT:

- 1) With no signal present at the input (open) measure TP1 [TP2] with the DVM #2 set to DC volts.
- 2) Adjust VR4L [VR4R] until DVM reads 0.00Vdc.

POWER SUPPLY TEST:

- 1) With DVM set to DC volts measure the positive end of C29. It should be less than +30Vdc.
- 2) With DVM set to DC volts measure the negative end of C28. It should be less than -30Vdc.
- 3) With DVM set to DC volts measure pin-4 of U11. You should read +15Vdc (+/- 0.5Vdc).
- 4) With DVM set to DC volts measure pin-11 of U11. You should read -15Vdc (+/- 0.5Vdc).

UNITY ADJUSTMENT:

- 1) Input a signal of 5000Hz (-10dBu) into the input and adjust VR3L [VR3R] for a reading of -14.00dBu as read by DVM #1.
- 2) Input a signal of 500Hz (-10dBu) into the input and adjust VR5L [VR5R] until DVM #1 reads -11.00dBu.
- 3) Repeat steps 1 through 2 as some interaction exists

LO-CONTOUR TEST:

- 1) Input a signal of 50Hz (-10dBu) into the input and adjust the LO-CONTOUR control to the middle position marked "0". DVM #1 should read -8.00dBu (0.260Vrms)(tolerance = +/- 1.0dBu).
- 2) Turn the LO-CONTOUR to "-" (minimum) you should read -22dBu on DVM #1.(+/- 1.0dBu).
- 3) Turn the LO-CONTOUR to "+" (maximum) you should read 0dBu on DVM #1 (+/- 1.0dBu).

DETECTOR CHECK:

- 1) Input a 5000Hz signal -10.0dBu (0.245Vrms) into the input.
- 2) With DVM #2 (set to DC volts) measure TP1 [TP2]. The meter should read +0.480Vdc (+/- 40mVdc).
- 3) Input a 500Hz signal -10.0dBu (0.245Vrms) into the input. DVM #2 should read +0.120 (+/- 40mVdc).

MANUAL PROCESS SWITCH TEST:

- 1) Switch the PROCESS switch to MANUAL.
- 2) Input a 500Hz signal (-10dBu) into the input.
- 3) With the DEFINITION control to MAXIMUM with the DVM #1 measure TP1 [TP2].
- 4) The DVM should read 0.400VDC (+/- 0.030VDC).
- 5) Measure the output with DVM #2. It should read -3dBu (+/- 1dBu)
- 6) Return the DEFINITION control to MINIMUM

CLIP INDICATOR ADJUSTMENT:

- 1) Input a 500Hz signal into the input with an amplitude of 7.75Vrms. (+20dBu)
- 2) Adjust VR6L [VR6R] until the CLIP indicator just turns on. If the LED is already on, adjust VR6L [VR6R] until the LED goes out and then bring it back up until it just turns on. (+19dBu should turn it off {6.90Vrms})

XLR BALANCED/UNBALANCED TEST:

- 1) With a balanced connection insure the unit functions normally as described above.
- 2) With an unbalanced connection insure the unit functions normally as described above.

BYPASS CHECK:

- 1) Switch the FUNCTION switch to the OUT position.
- 2) Since the model 822 has "hard wire" bypass whatever is present at the input of the device should be present at the output when in bypass mode. Verify that this is so.

DC VOLTAGE AT OUTPUT TEST:

- 1) Measure the output jacks to ground with the DVM set to DC volts the voltage must be 0.00Vdc. On the XLR connectors both pins 2 and 3 should be 0.00Vdc.

LED Test:

- 1) Input a 5000Hz signal (@ -10dBu) into the connector marked CHANNEL A [B] INPUT. The green (+) led should light.
- 2) Input a 500Hz signal (@ -10dBu) into the connector marked CHANNEL A [B] INPUT. The red (-) led should light.
- 3) Disconnect the signal input and the amber (0) led should light
- 4) With the FUNCTION switched to the IN position the corresponding green LED should be lit.
- 5) With the FUNCTION switched to the OUT position the corresponding amber LED should be lit.

OFFSET DRIFT TEST:

- 1) With no signal present at the input (open) measure TP1 [TP2] with the DVM set to DC volts.
- 2) Insure this voltage is 0.00Vdc (+/- 0.25mVdc)

THIS COMPLETES THE CALIBRATION OF THE BBE™ MODEL 822A

Service

We recommend that if at all possible a BBE 822A which requires repair be sent to our facility in Huntington Beach, CA. We request that a "RETURN AUTHORIZATION" be issued by the dealer from whom you purchased the unit. If this is not possible, call BBE Sound, Inc. directly to obtain a "RETURN AUTHORIZATION" and included with the unit a copy of the bill of sale so that this process can be expedited.

As the repair turnaround time is minimal, we request that the unit be sent to BBE Sound, Inc. We also need to add reliability data to our files so that future revisions may be undertaken if necessary to improve the product.

Warranty

The BBE 822A Processor is warranted against defects in material and workmanship for a period of one (1) year from date of purchase from BBE Sound, Inc. or from an authorized dealer.

During this period, we will repair units free of charge providing that they are shipped prepaid to BBE Sound, Inc., 5500 Bolsa Ave, Suite 245, Huntington Beach, CA 92649. We will pay return UPS shipping charges within the USA. All charges related to non-US shipping, including customs clearance, will be billed.

This warranty will be considered null and void by BBE Sound, Inc. if any of the following is found:

1. The equipment has been physically damaged.
2. The equipment shows signs of abuse.
3. The equipment has been electrically damaged by improper connection or attempted repair by the customer or a third party.
4. The equipment has been modified without authorization.
5. The bill of sale indicates that the purchase date of the equipment is not within the warranty period.

BBE Sound, Inc. is NOT LIABLE FOR CONSEQUENTIAL DAMAGES. Should the processor fail to operate for any reason, our sole obligation is to repair the unit as described above.

Maintenance

Maintenance of the BBE 822A is limited to proper cleaning of the unit with mild household cleaner such as Formula 409tm or Windextm. The chassis and cover are steel finished with a durable polyurethane paint, while the front panel is an anodized aluminum extrusion.

There are no user replaceable parts and the unit should not be opened for any reason unless you are a qualified technician.

Calibration should be performed if parts are replaced or if a performance check-out indicates a problem with calibration. Long term use has shown that over the life of the unit there is little or no drift of the components in the BBE 822A which would cause a change in calibration. A very conservative design philosophy has resulted in a piece of equipment which runs very cool and should give years of trouble-free service.

FIGURE 1
RECORDING STUDIOS

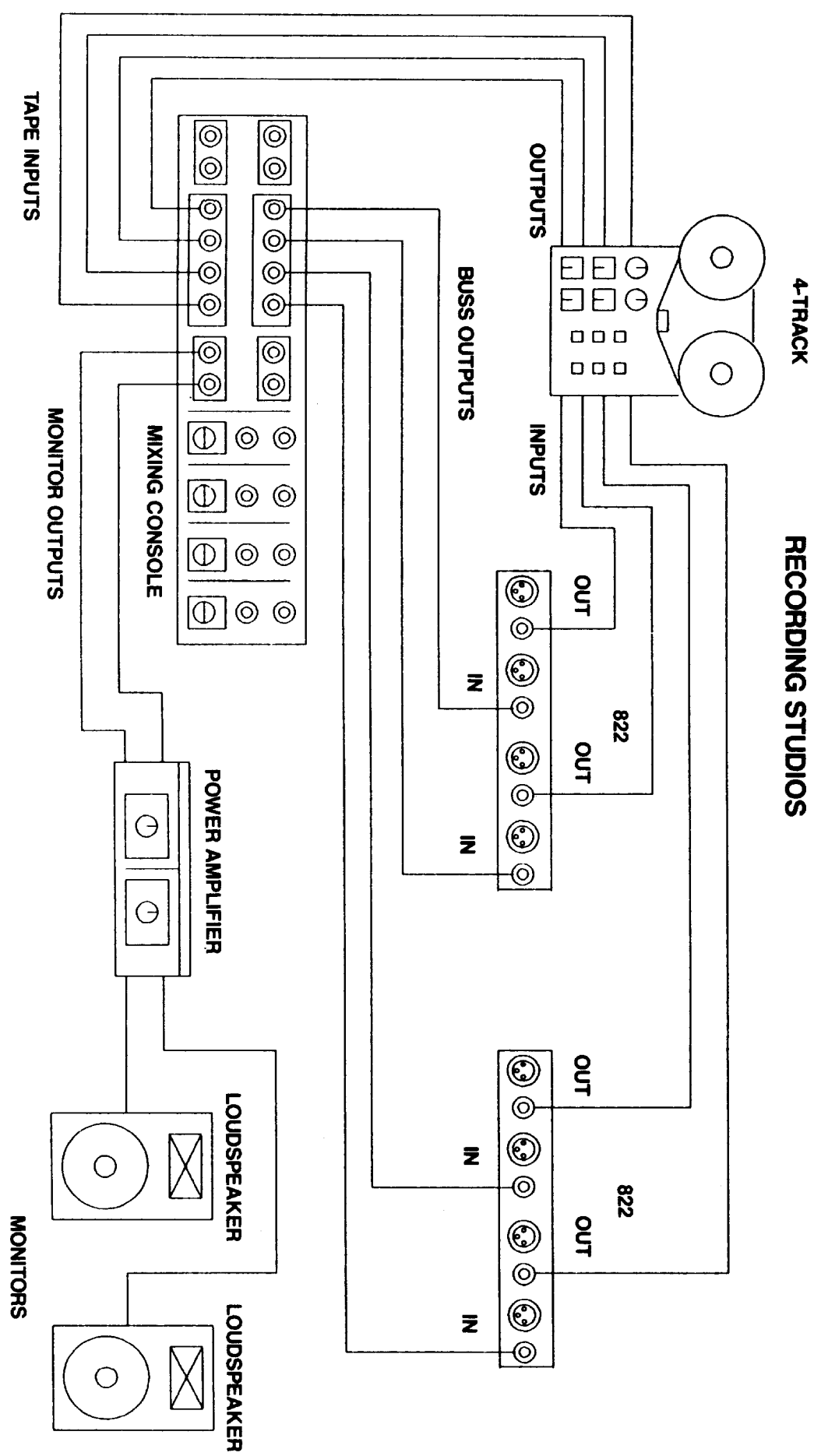

FIGURE 2
CONCERT SOUND SYSTEM

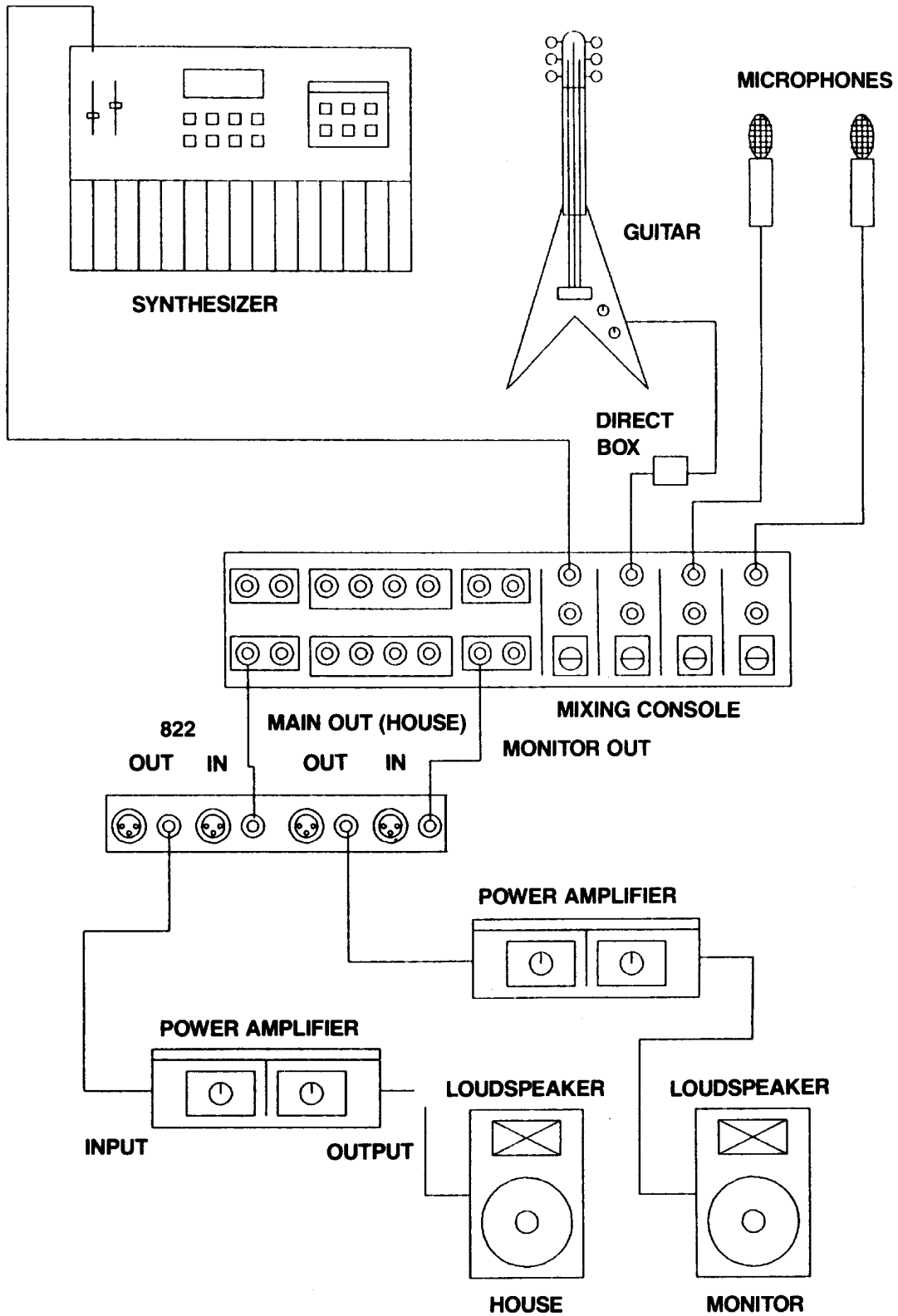

FIGURE 2B

822A

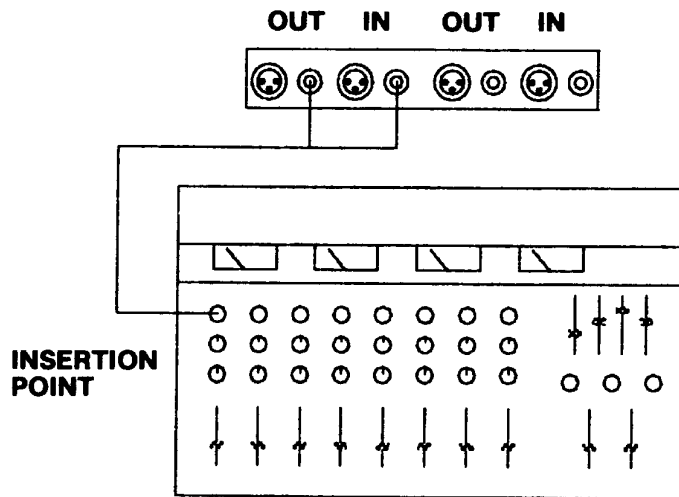

FIGURE 3

2-TRACK

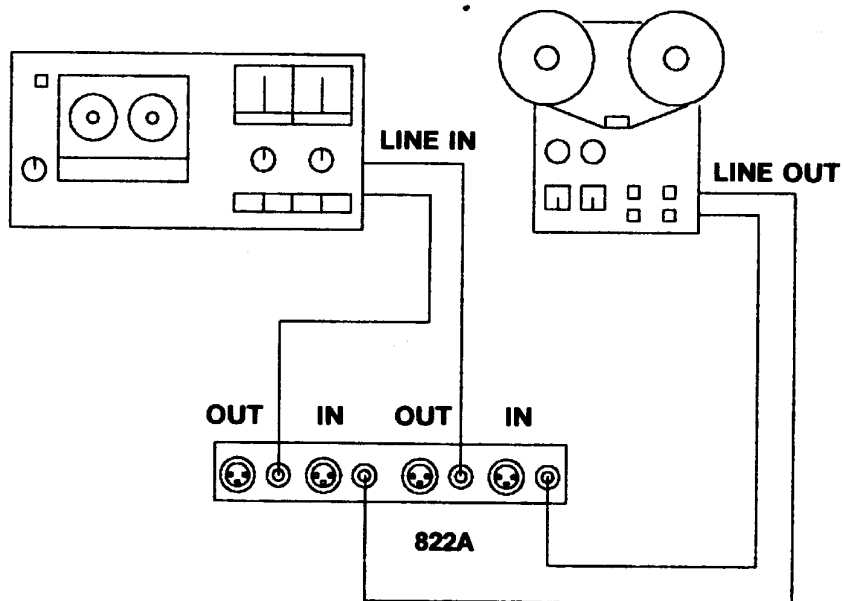

FIGURE 4

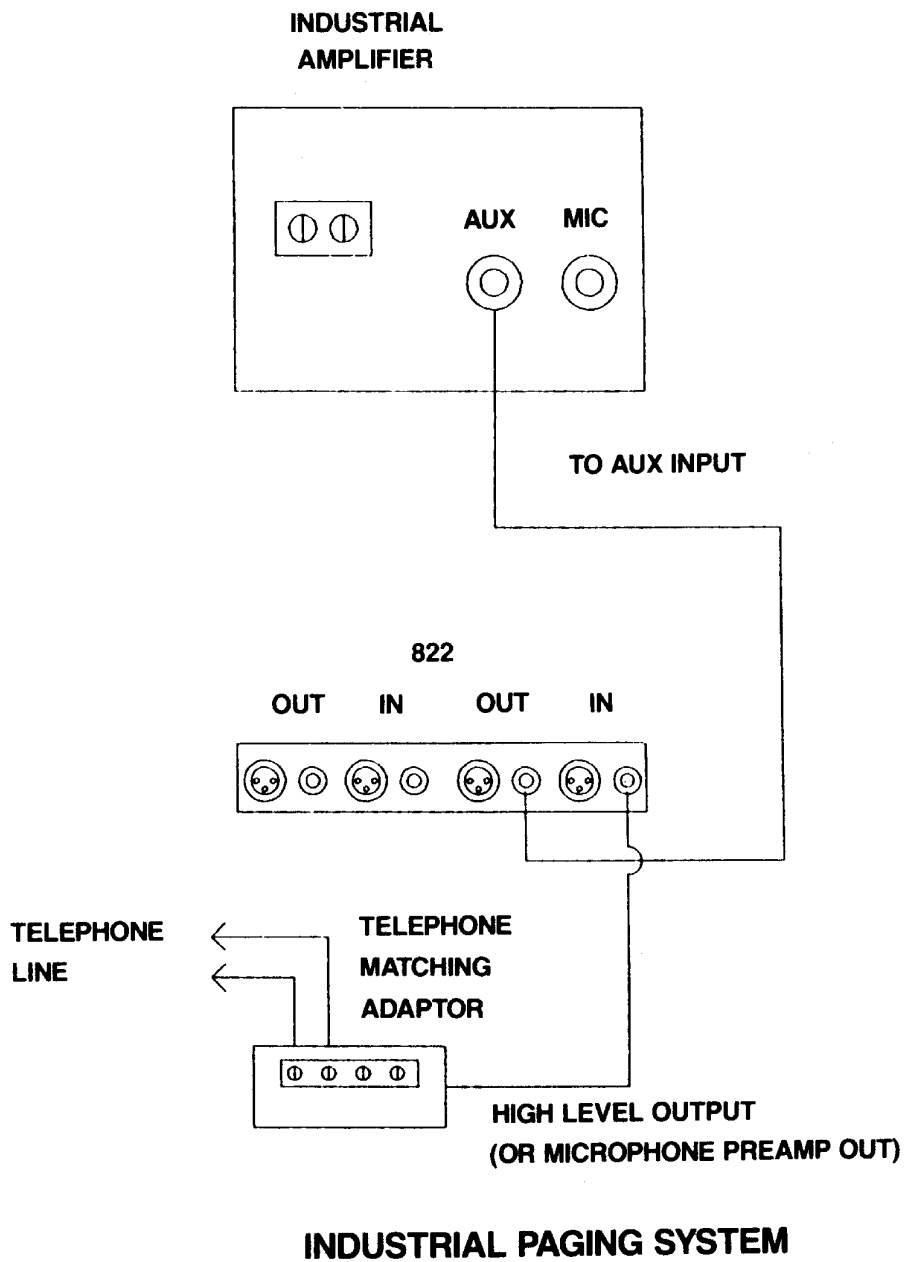

FIGURE 5

BROADCAST APPLICATION

RADIO CONSOLE

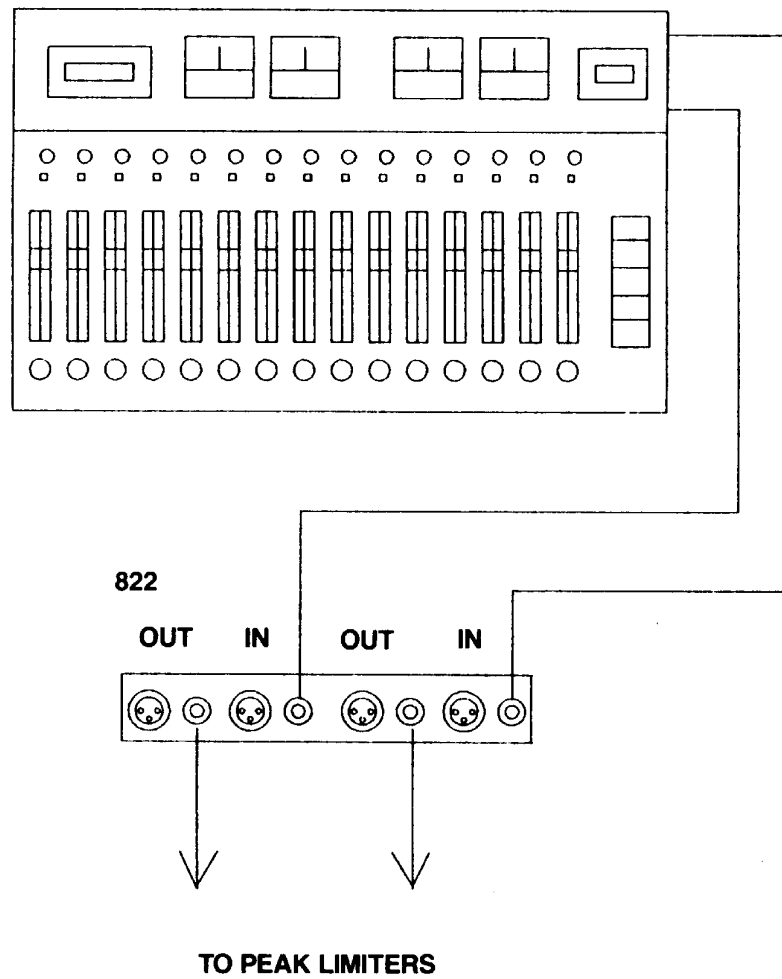

FIGURE 6

MOVIE THEATER APPLICATIONS

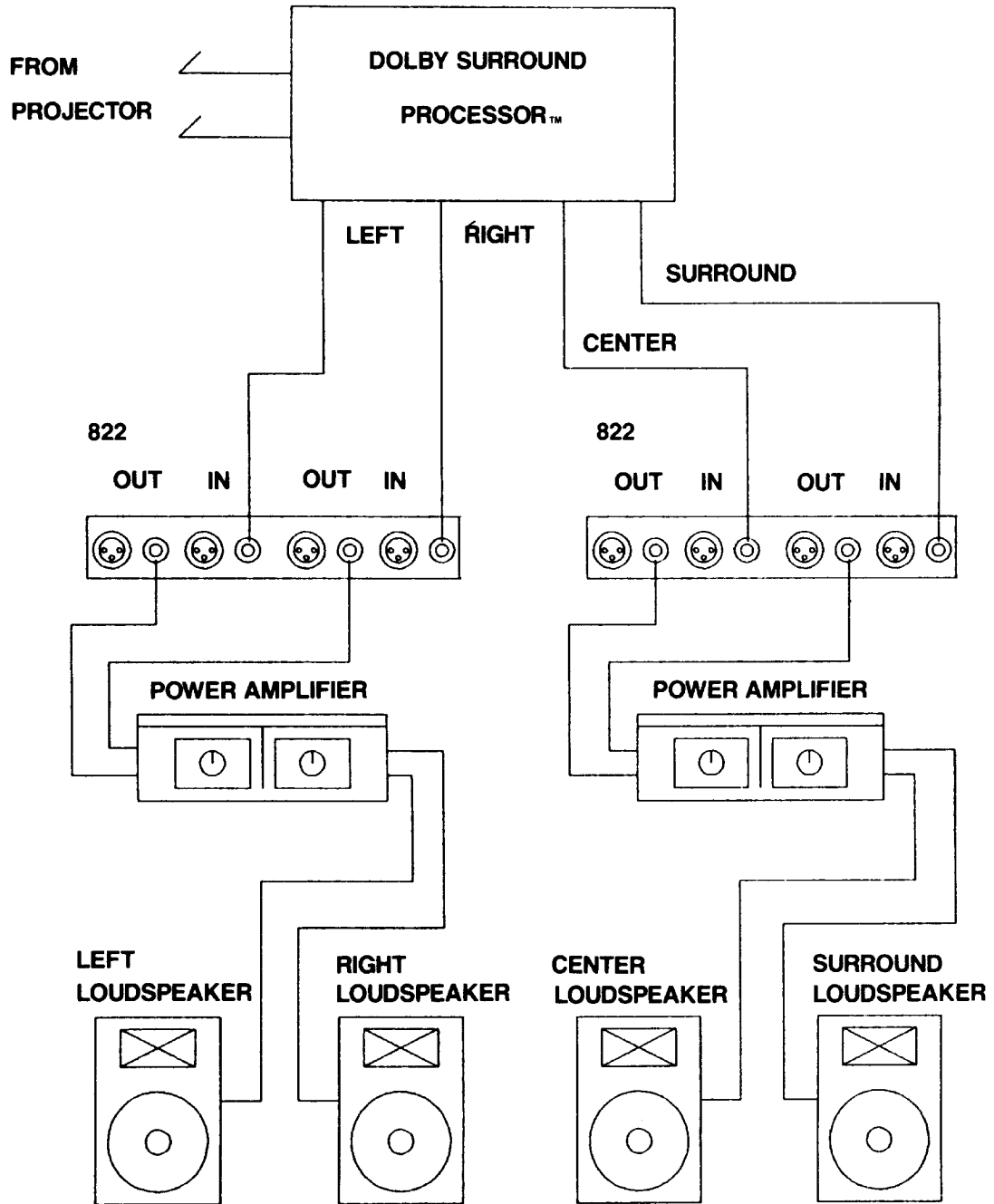

FIGURE 7
DISCO CLUB APPLICATION

